

Project Name	
Project #	
Model #	
Type	

## FWS-U036-ET2003 LED Series

### FEATURES & SPECIFICATIONS

**Intended Use:** The ET2155 series is an excellent choice for powerful and energy efficient wall sconce. These fixtures are made with LED chips and an aluminum body with powder coating finish to provide a long lasting, beautifully built fixture capable of meeting your wall lighting needs.

**Installation:** These luminaries are ideal for indoor/ outdoor lighting and site lighting.

**Rating:** Wet Location

**Warranty:** 5 years

<b>Housing</b>	Die-cast aluminum
<b>Baffle Faceplate</b>	Die-cast aluminum
<b>Gasket</b>	Silicone rubber
<b>LED Optic</b>	PMMA Lens
<b>Surface Finish</b>	AkzoNobel powder coating
<b>Driver Type</b>	Constant current
<b>Input Voltage</b>	120~277V/AC
<b>Ambient Temperature</b>	-20°C~45°C
<b>Beam Angle</b>	Asymmetric
<b>Ingress Protection</b>	IP65

Certifications 

### Dimensions

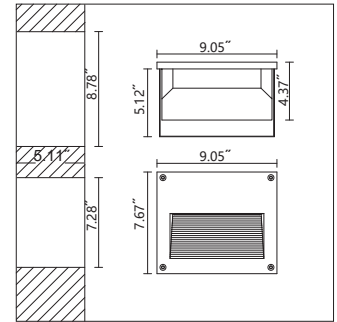

### Housing Color



Black RAL9011 White RAL9016 Gray RAL7012 Mineral bronze Silver RAL9006

### Photometric Data

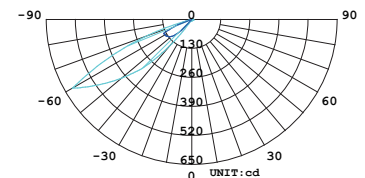

## ORDERING INFORMATION

**EX: FWS-U036-ET2155-008-27V-40K-B**

Series	Wattage (Lumen:	Input Voltage	Temperature	Sensor	Finish
1a. FWS-U036-ET2155	2a. 008 (8W; 600lm)	3a. 27V	4a. 30K (3000K)	5a. (N/A)	6a.B
			4b. 40K (4000K)		6b. W
			4c. 50K (5000K)		6c. G
					6c. Z

Notes:

\*If you do not see an option you would like please inquire directly and we will work to accommodate your needs.\*

3a. 120V-277Vt      6a. Black      6c. Grey      6e. Silver  
 6b. White      6d. Mineral Bronze

\*All of the products and specifications can change without prior notice\*

\*Please note this specification sheet is considered to be business promotional material and not used for product listing identification purposes\*