

Project Name	
Project #	
Model #	
Type	

FTP-CL03 LED Series

FEATURES & SPECIFICATIONS

Intended Use: The CL03 series is an excellent choice for powerful and energy efficient site lighting. These fixtures are made with positive cooling technology to maximize the lifetime of the fixture. These fixtures are made with high quality SMD LED to provide a long lasting, beautifully built fixture capable of meeting your site lighting needs. The wide range of wattages ensure that there's a lighting option for any application you have.

Installation: These luminaries are ideal for parking lots, Area Lighting, Parks, Walkways, and other outdoor area lighting.

Rating: IP54

Warranty: 3 years

Listings: UL

View Angle: 360°

CRI: >70

Fixture Body: Die-cast Aluminum

Dimensions: (L x W x H)

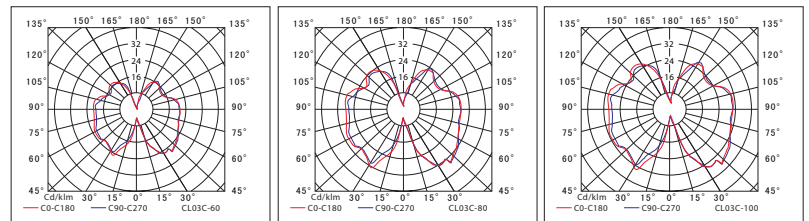
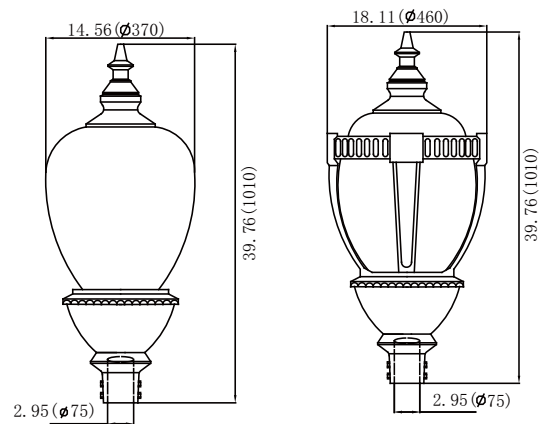

ORDERING INFORMATION EX: FTP-LDA-050-UNV-50K-BLK-SFPB

Series	Wattage (Lumens)	Input Voltage	Temperature	Options	Finish	Mounting
1a. FTP-U076-LC03A	2a. 040 (40W; 3,400lm)	3a. 27V	4a. 27K (2700K)	5a. (Blank)	6a. BLK	7a. PB
1b. FTP-U076-LC03B	2b. 060 (60W; 5,100lm)		4b. 30K (3000K)	5b. MWS	6b. WHT	
1c. FTP-U076-LC03C	2c. 080 (80W; 6,800lm)		4c. 41K (4100K)		6c. BRZ	
	2d. 100 (80W; 8,500lm)		4d. 50K (5000K)			
			4d. 65K (6500K)			

Notes:

*If you do not see an option you would like please inquire directly and we will work to accommodate your needs. *

3a. 100 - 277V input voltage 5a. Leave blank if not needed 5b. Motion Sensor 6a. Black 6b. White 6c. Bronze 7a. POLE BRACKET

Please note this specification sheet is considered to be business promotional material and not used for product listing identification purposes

All of the products and specifications can change without prior notice