

| | |
|--------------|--|
| Project Name | |
| Project # | |
| Model # | |
| Type | |

FDD-U066-D03 LED Series

FEATURES & SPECIFICATIONS

DESCRIPTION

The LED Dusk to Dawn combines optical performance, energy efficiency and versatility to meet the needs of any area. It features a power door for easy maintenance and 3G vibration rated construction. This LED solution provides uniform and energy conscious illumination for municipal streets, commercial and perimeter lighting.



Construction

- Durable, die-cast aluminum housing dark bronze polyester powder-coat finish
- Twist-lock photocell included

Recommended use

- General Area Illumination
- Entryways & Pathways
- Yards & Loading Docks

Electrical

- Input Voltage: 120-277V
- Operating Temperature Range: -40°C - + 45°C (-40°F - + 113°F)

Listing

- cULus Listed
- Suitable for wet locations

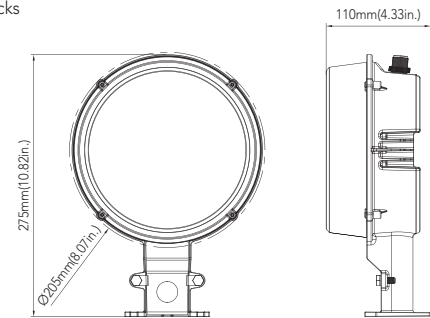

ACCESSORIES



PHOTOMETRICS

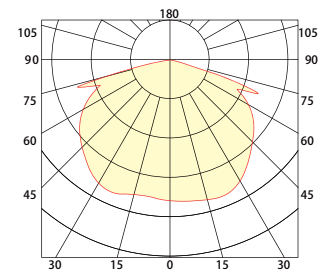

ORDERING INFORMATION

EXAMPLE: FDD-U066-D03-050-27V-50K-PP0-SG

| Series | Wattage (Lumens) | Input Voltage | Temperature | Options | Finish | Mounting |
|------------------|------------------------|---------------|-----------------|-----------|--------|----------|
| 1a. FDD-U066-D03 | 2a. 027 (27W; 3,520lm) | 3a. 27V | 4a. 40K (4000K) | 5a. Blank | 6a. D | 7a. PB |
| | 2b. 040 (40W; 5,200lm) | | 4b. 50K (5000K) | 5b. P0 | 6b. B | |
| | | | | | 6c. SG | |

Notes:

*If you do not see an option you would like please inquire directly and we will work to accommodate your needs. *

3a. 100 - 277V input voltage 5a. leave blank in not needed 5b. 120-277V Photocell 6a. Dark Bronze 6b. Black 6c. Silver Gray 7a. Included

Please note this specification sheet is considered to be business promotional material and not used for product listing identification purposes

All of the products and specifications can change without prior notice